

AMERICAN REINFORCED PLASTICS

SPECIFICATIONS FOR

MODEL#: **S-6037-AST-KD**

60" SPECIAL ACCESS, Barrier Free Shower, 3-PIECE REMODEL UNIT

COMPOSITION

American Reinforced Plastics bath products are manufactured using specially formulated sanitary polyester gel coat, backed with a heavy fiberglass reinforcing. The surround portion is a sandwich panel construction with a polyurethane core, built to exceed the standards of A.N.S.I. Z 124-1, Z 124-2, and UPC-11-60. Laminated wood panels are used in floor and grab bar and seat reinforcement.

DESIGN FEATURES

The SPECIAL ACCESS 60" Modular stall is 3-piece construction, ideal for remodeling situations. The S-6037-AST-KD is designed to transform most existing 5 ft. bathtub/shower applications into a wheelchair accessible, barrier free application. The base is factory pre-levleled for easy installation and long term reliability. Ideal for residential or commercial use. Stainless steel grab bars can be installed as shown, or custom to order. Extra wood reinforcement is laminated into the side walls for additional strength and support. Seats may be mounted on the left or right side upon customer request.

MAINTENANCE

Only easy to use liquid cleaners are required to maintain the bright, smooth surface in a like new condition. Avoid using abrasive cleansers.

WARRANTY

ARP units have a five year warranty against factory defects.

ARCHITECTS SPECIFICATIONS

The bathing enclosure shall be manufactured by American Reinforced Plastics, Inc., 8209 Pacific Highway East, Tacoma, Washington, 98422. Telephone (253) 922-5808. The enclosure shall be wheelchair accessible, multi-piece, made of heavy-duty, fiberglass reinforced polyester gel-coat, to provide a sanitary smooth surface. Wood reinforced wall panels shall be used to accept grab bars and seat installation. Measurements, hardware, and structural integrity shall meet all requirements and standards as specified in A.N.S.I. 117. Special reinforcing, contouring and sandwich panel construction with a structural core gives strength to exceed A.N.S.I. Z 124-1, Z 124-2 and UPC - 11 - 60 standards. The units shall be self-supporting and the walls shall have nailing flanges on front and top edges. Warranty against factory defects shall be five years. The under portion of the enclosure shall be coated with an integrated resin compound to provide stable bearing against the floor, allowing no give to the bottom when installed.

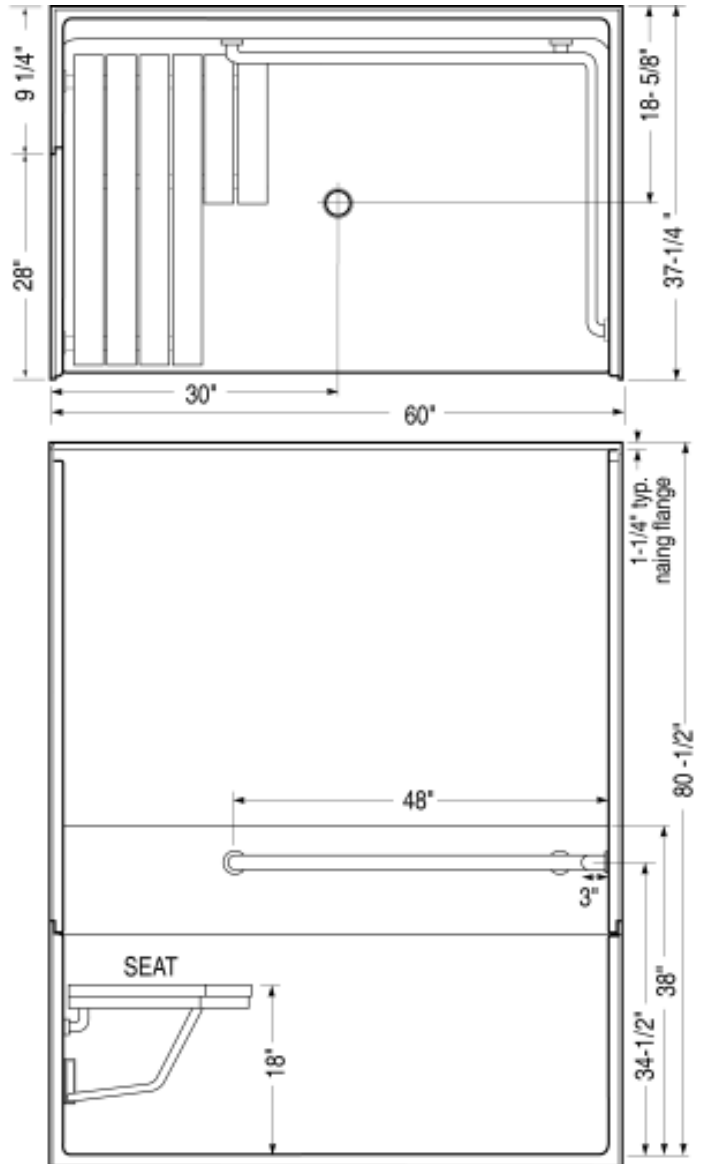
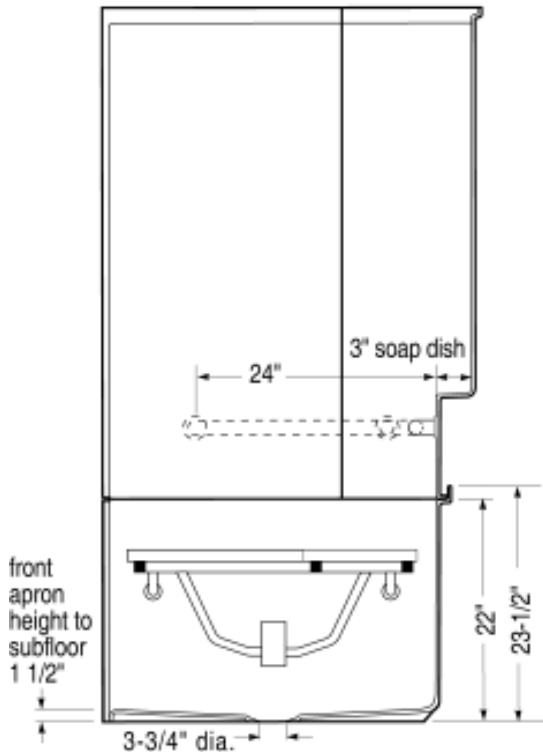

© 2009 AMERICAN REINFORCED PLASTICS

8209 PACIFIC HWY. EAST, TACOMA, WA 98422 • (253) 922-5808 • FAX (253) 922-2036 • WWW.ARPBATHTUBS.COM